

# THESE INSTRUCTIONS MUST BE PLACED IN TRUCK CAB

## SCORPION 10,000 TMA

### OPERATOR'S DEPLOYMENT INSTRUCTIONS

1. For operation, truck driver/operator will plug in hand held operating control located at right side rear of the truck and raise or lower the TMA.
2. Before travel to or from work zones, TMA must be hydraulically powered to the full stop position on the support post. **(Continue to push the up button for two seconds after stopping point is reached to ensure a full power lock.)**
3. For deployment of TMA (0-30 mph.), truck driver/operator must ensure the TMA is locked into the horizontal position by action of the hydraulic system. When fully deployed, the hydraulic pressure cut-off system will ensure the TMA is set and locked into position. **(Continue to push the down button for two seconds after stopping point is reached to ensure a full power lock.)**
4. For deployment of TMA in stationary applications, truck driver/operator must ensure truck is parked with the emergency brake on and is engaged in gear or park.
5. For night operation, truck driver/operator must check and ensure that the side and rear light markers are switched on via the truck light switches.
6. On completion of the deployment, truck driver/operator must check for clearance before retracting the TMA to its' fully folded position.
7. Truck driver/operator must ensure that the TMA is hydraulically powered to the full stop position on the support post before travel. **(Continue to push the up button for two seconds after stopping point is reached to ensure a full power lock.)** Disconnect the hand held operation control unit from the truck.

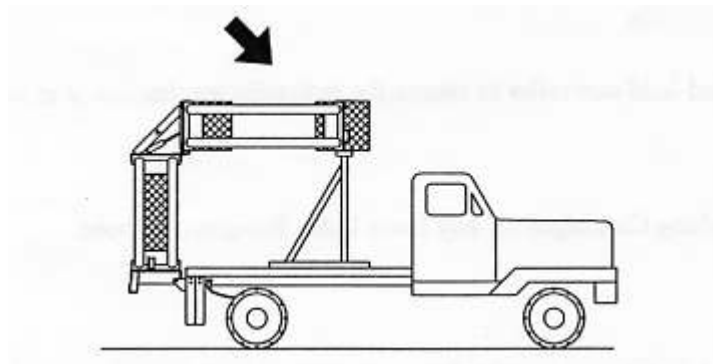

**MUST BE FULLY POWERED DOWN  
FOR TRAVEL 0 TO 60 MPH**

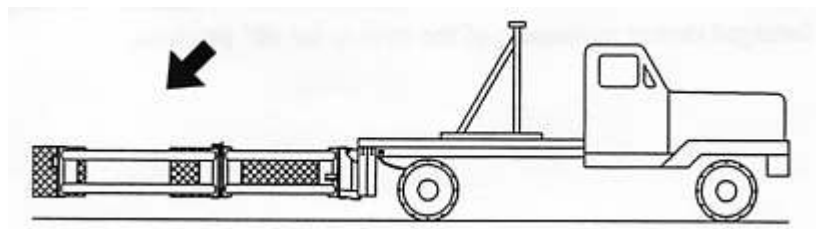

**MUST BE FULLY POWERED DOWN  
FOR DEPLOYMENT 0 TO 30 MPH**