



**TraFFix  
Devices Inc.**

*Engineered Products for Safer Highways*

# ATTENUATOR

## PRODUCT GUIDE



[www.traffixdevices.com](http://www.traffixdevices.com)

# Table of Contents

<b>Delta® Intelligent Crash Cushion</b>	<b>1</b>
<b>Sentinel® Impact Tracker</b>	<b>3</b>
<b>HV2 Barrier</b>	<b>5</b>
<b>Scorpion® II Truck Mounted Attenuator</b>	<b>7</b>
<b>Scorpion® II Blocker</b>	<b>11</b>
<b>Scorpion® II Metro</b>	<b>12</b>
<b>Scorpion® II Metro-Slim</b>	<b>14</b>
<b>Scorpion® TMA Fast-Trak SwiftConnect™</b>	<b>15</b>
<b>Scorpion® TMA Mounting and Support</b>	<b>16</b>
<b>Scorpion® TMA Arrow/Message Board Mounting Systems</b>	<b>17</b>
<b>Scorpion® II Towable Attenuator</b>	<b>18</b>
<b>SLED™</b>	<b>20</b>
<b>SLED™ Mini</b>	<b>24</b>
<b>SLED™ Euro-Terminal</b>	<b>26</b>
<b>Big Sandy® Sand Barrels</b>	<b>28</b>
<b>TraFFix Sentry™ Water-Cable Barrier</b>	<b>31</b>
<b>TraFFix Water-Cable Barrier</b>	<b>33</b>
<b>Lo-Ro® Water-Cable Barrier</b>	<b>34</b>
<b>TraFFix Water-Wall™ LCD</b>	<b>35</b>
<b>TraFFix Water-Wall and Water-Wall Fence</b>	<b>37</b>
<b>Urbanite®</b>	<b>38</b>
<b>ADA Wall®</b>	<b>39</b>







— INTELLIGENT CRASH CUSHION —

Co-Developed with:

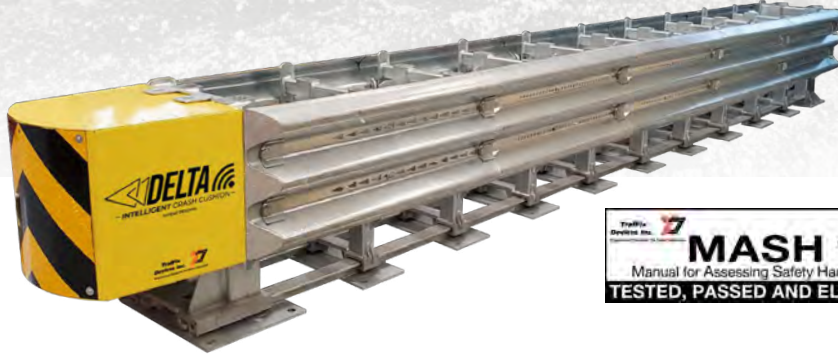

**Delta® Intelligent Crash Cushion**  
 Redirective Non-Gating Crash Cushion  
 MASH Tested, Passed and Eligible TL-3.

**Significantly Simple**



- No Hydraulic Cylinders
- No Cartridges
- No Modules
- No Cables
- No Pulleys
- No Tension Bars

**First Ever  
 "Connected Crash Cushion"**

The Sentinel® Impact Tracker now comes as standard equipment on every DELTA Intelligent Crash Cushion.



**Attenuating Energy, Simply**

Attenuates energy with shear bolts tearing through cut-outs of various sizes & shapes.





## Easiest Installation Process

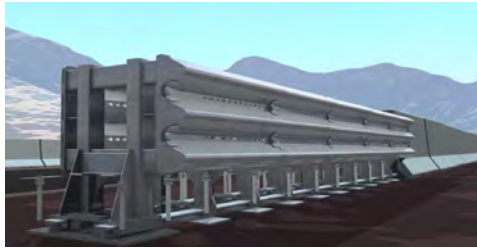

Works as its own template. Set in place, drill and install 39 anchor bolts.



Comes almost completely pre-assembled. After anchor bolts are installed, attach the nose module with 4 bolts.

## Uncompromised Testing Integrity

All tests performed at a third party ISO Certified Facility.

<p><b>3-30</b> Small Car, 0° Angle, 1/4 Offset</p>	<p><b>3-31</b> Heavy Truck, 0° Angle, Centered</p>	<p><b>3-32</b> Small Car, 15° Angle, Centered</p>
<p><b>3-33</b> Heavy Truck, 15° Angle, Centered</p>	<p><b>3-34</b> Small Car, 15° Angle, CIP 1 FT. Downstream from Upstream End</p>	<p><b>3-35</b> Heavy Truck, 25° Angle, CIP 1 FT. Downstream from Upstream End</p>
<p><b>3-36</b> Heavy Truck, 25° Angle, CIP 7 FT. Downstream from Upstream End</p>	<p><b>3-37a</b> Heavy Truck, 25° Angle, Reverse CIP 4.3 FT. Downstream from Upstream End</p>	<p><b>3-38</b> Mid-size Car, 0° Angle, Centered</p>

## Significantly Simple and Safe

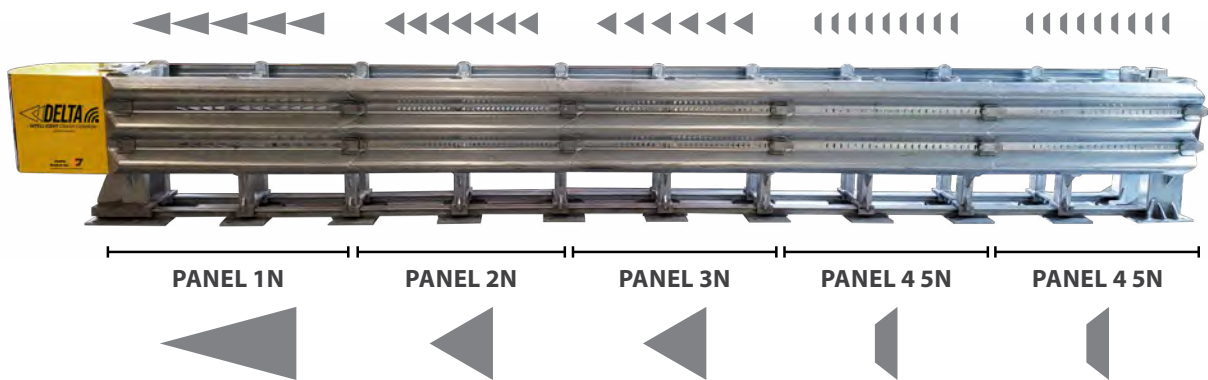

Easily change sheeting direction on the Object Marker in the field.



## SPECIFICATIONS

Length:	21 ft. / 6.4 m
Height:	32 in. / 813 mm
Width:	30 in. / 762 mm
Weight:	2,270 lbs. / 1,030 kg





# Sentinel<sup>®</sup>

## IMPACT TRACKER

# NEVER MISS AN IMPACT

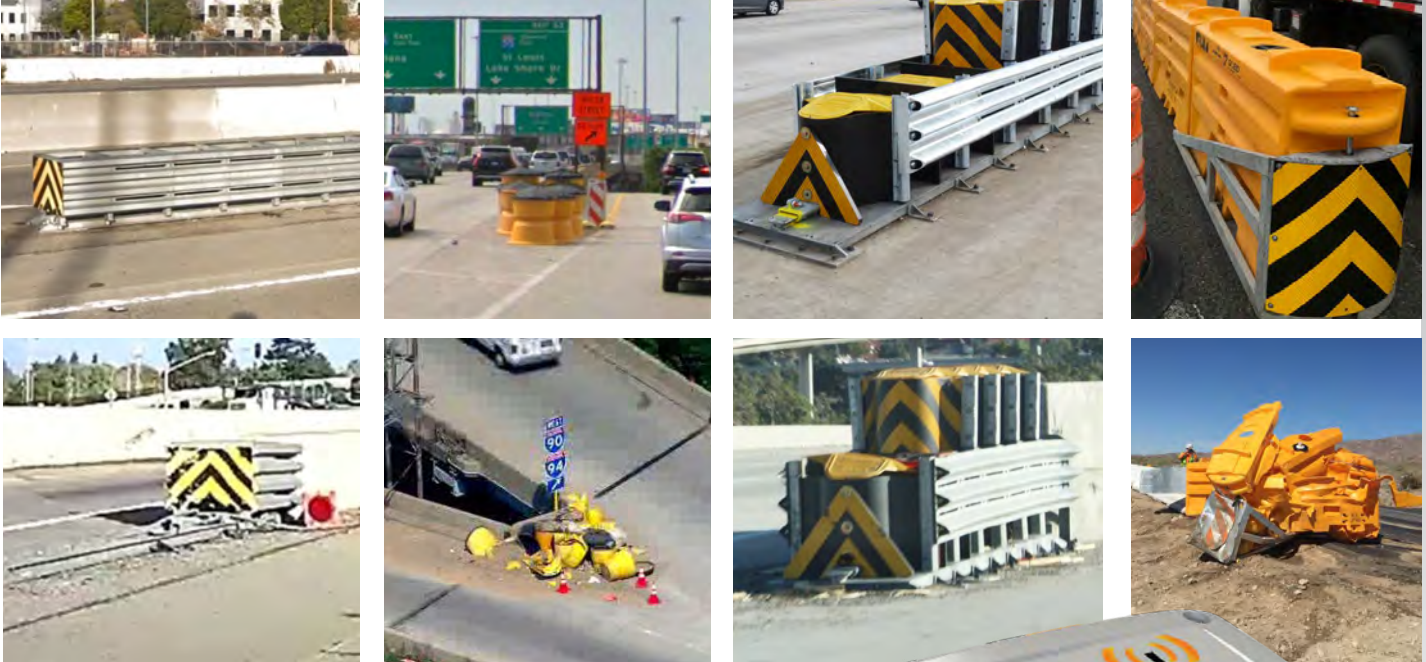

- Get immediate notification without having to rely on other agencies or personnel to report impacts
- 24/7 Monitoring of permanent and temporary attenuators, terminals, barriers, roadside signs etc.
- Immediate notification via text and/or e-mail, upon impact Easily attaches to most attenuators
- Powered by a 5 year lifespan battery
- Weatherproof & durable
- Updated remotely via cellular download
- Self-contained compact device
- Reports accelerations above a set threshold
- Works on most highway hardware including guardrail, barrier wall & signs
- Tune-able to work with most common permanent and temporary attenuators



# Sentinel® Dashboard

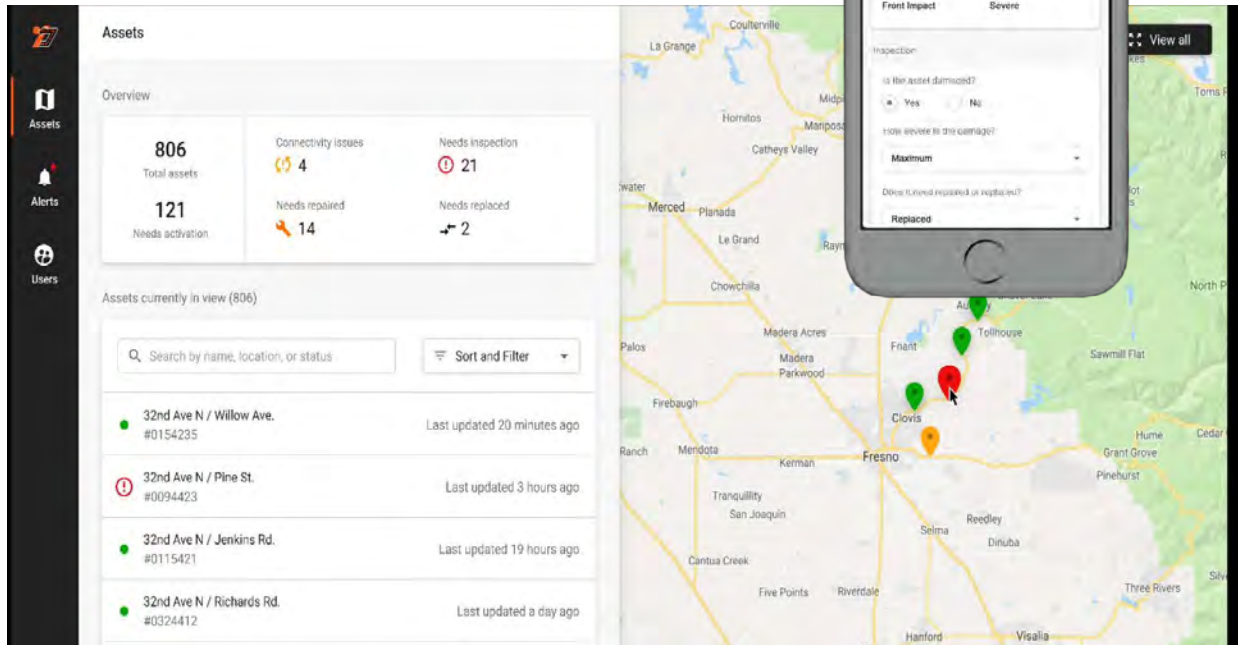

01



Connect

Connect to all types of crash cushions or attenuators with ease.

02



Monitor

Monitor the status of your crash cushion with a simple, easy to use interface from any device.

03



Impact

The Sentinel transmits a signal upon impact, alerting maintenance personnel.

04



Alert

An alert is sent to multiple devices with the exact location of the impacted crash cushions.

- Map of all monitored devices with colored pins.
- “Zoom In” to specific devices to get:
  - Date of install
  - Type of device
  - Serial Number
  - Maintenance and repair history
  - Picture of device as installed
- Real Time reporting of incidents / impacts
- Data provided to assist in Revenue Recovery







## Durability of Steel with No Pins or Anchors

The HV2 Barrier is the ultimate freestanding, temporary longitudinal barrier system, bringing improved productivity and safety to worksites. The barrier's patented hybrid technology and unique connectors offer high containment and low deflection, while remaining economical to transport and deploy with no time-consuming anchoring required.



Durability of steel - freestanding - no anchors required



HV2 Barrier can be used with a variety of end treatments

- MASH TL-4 tested, passed and eligible
- 100% freestanding system with the SLED end treatment and stiffening beams
- High containment ability with safe redirection
- Excellent choice for concrete bridge decks with no potential damage to the rebar
- Designed to perform without being anchored to a road surface - barrier uses its weight distribution to contain vehicles upon impact
- Can be used on any flat surface
- Economical to transport, install, and retrieve
- Connection system between barriers is extremely simple, without any need for pins or bolts
- Only the damaged barrier needs to be replaced, making them extremely economical



Compatible with the Sentinel Impact Tracker to create an Intelligent Steel Barrier!



HV2 Barrier can be used with a variety of end treatments



## HV2 Barrier

### Specification

HV2 Safety Barrier is a free standing temporary longitudinal barrier system successfully crash tested to MASH TL-3 & MASH TL-4. The patented hybrid technology, and unique connectors, allow it to offer high containment and low deflection, while remaining economical to transport and deploy. HV2 Safety Barrier also provides safe, consistent and reliable redirection, fast deployment and retrieval. No anchoring is required with no loose parts making it maintenance free with the durability of galvanized steel.

HV2 Safety Barrier is tested to provide positive protection of work sites by safely redirecting errant vehicles up to 22,000 lbs (10,000kg) at 15° and 56 mph (90 km/h), or 5,000 lbs (2,270 kg) at 25° and 62 mph (100 km/h). This allows HV2 Safety Barrier to be suitable for use on any roadside work zone from highways to low-speed local streets. It can be used on any firm surface including concrete, asphalt, spray seal, unsealed compound pavements, and uniform natural surfaces.

HV2 Safety Barrier is constructed from a series of individual barrier segments. Each segment is constructed from galvanized steel with required concrete ballasting. Segments are fastened by integrated, interlocking bidirectional connectors, which simply slides together when barriers are lowered into position.

HV2 Safety Barrier installations require a minimum deployment length of 323.5ft/98.6m (17 interlocking, ballasted HV2 Barrier units) plus the required end treatments, to safely contain and redirect at MASH TL3. For MASH TL-4 the minimum Deployment is 912ft/278m (48 interlocking, ballasted HV2 Barriers) plus the required end treatments.

### MASH Approval

HV2 Barrier has recieved federal eligibility as a MASH TL-4 device.

#### Federal Eligibility Letters:

- B306 - HV2 Transition to Crash Cushion MASH Test Level 3
- B308 - HV2 Barrier MASH Test Level 4

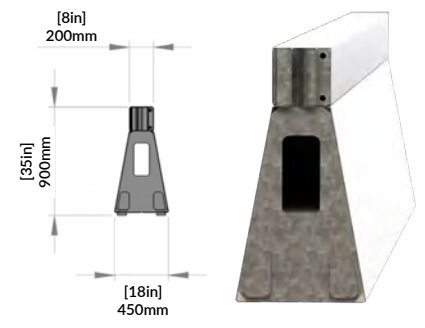





# Scorpion II<sup>®</sup> TMA

## Truck Mounted Attenuator



Scorpion II<sup>®</sup> TL-3 (100 kph)  
Truck Mounted Attenuator  
MASH Tested, Passed and Eligible



10000-TL3M-12(C, FBS or S)



### TL-3 Attenuator

- Over 2,000 documented hits involving Scorpions and thousands of lives saved around the world. Scorpion's Patented design has over twenty years of proven life saving performance on highways around the globe.
- Protect your workers with the safest, most reliable truck mounted attenuator available today.
- The FIRST Truck Mounted Attenuator eligible for MASH, TL-3 62.5 mph (100 kph). FHWA Eligibility Letter, CC-132, dated June 15, 2017.
- Full Width Impact Protection - Safely protects and redirects the impacting vehicle away from the "coffin corner" area at the rear of the truck.
- Curved Aluminum Tube Frame - Exceptionally strong, providing protection against nuisance impacts with re-directional capacity along the entire length of the TMA.
- Energy Absorbing Cushions - Aluminum honeycomb core, enclosed by aluminum powder coated modules providing maximum durability and longevity.
- Modular Design - When impacted, the Scorpion II crushes in progressive stages, which results in lower repair costs and easy parts replacement.
- Shortest Overall Length, only 13' (4 m) in use position when compared to other competitors units that are over 19' (5.8 m) long when fully deployed- minimizes incidental impacts which reduces repair costs.
- Open Cartridge Design - reduced wind resistance increases fuel efficiency in storage and transport mode, even when traveling at highway speeds.
- Tested and Eligible with a minimum host truck vehicle weight of only 15,000 lbs (6,804 kg).
- Infinite weight eligible - can be used on a host vehicle from 15,000 lbs (6,804 kg) with no upper weight limit.
- LED Lighting Standard - All lights are now LED, including tail lights, back up, turn signals and running lights.
- Available with optional Dr. Airbrake<sup>®</sup> automatic braking system, instantly locks brakes of host vehicle upon impact.



#### TL-3 SPECIFICATIONS

Length: 12.9 ft. / 3.9 m  
Width: 8.0 ft. / 2.4 m  
Height from the ground:  
12.0 in. ± 1.0 in.  
305 mm ± 25.4 mm

# Scorpion II TL-3 (62.5 mph/100 kph) Truck Mounted Attenuator

## Specification:

The Truck Mounted Attenuator (TMA) is a mobile crash cushion attached to the rear of a support vehicle's frame. The TMA may be used on moving shadow trucks, stationary block vehicles, or advanced warning vehicles upstream of a moving or stationary operation. The TMA shall be tested, passed and eligible to MASH TL-3 (62.5 mph / 100 kph). The TMA can be used on support vehicles with a min. actual/curb weight of 15,000 lbs (6,804 kg) with no upper weight limit (infinite weight). Lighting consists of LED brake, directional, signal and running lights for enhancement of advanced warning to drivers. The TL-3 TMA has an overall dimension of 12.94 ft. (3.9 m) x 8.0 ft (2.4 m) x 2.0 ft (0.6 m) and has a ground clearance of 12 in ± 1 in (305 mm ± 25.4 mm) when deployed in the horizontal operating position. The Scorpion II TMA consists of three (3) main components: Strut, Cartridge, and backup/diaphragm frames. The Strut and Cartridge are the energy attenuation components. The Strut is positioned nearest to the support vehicle and the Cartridge is positioned furthest away from the support vehicle. The Cartridge is typically the first component impacted by an errant vehicle. The Strut consists of four (4) outboard convex aluminum tubes (two on each side) forming an aluminum structural weldment. The aluminum structural weldments bolt to a structural steel diaphragm/backup frame. The TMA can be rotated in a double 90° fold position over the support vehicles bed with a stored height of less than 12'5" (3.8 m). An optional hydraulic powered vertical lift can be utilized with the TMA to deploy a display panel when the TMA is lowered into the use position. The vertical lift is powered by the same onboard hydraulic system that rotates the TMA into the stored and use position. The vertical lift is sequenced to raise and lower a panel for displaying advanced messages, directional indicators, or other notifications.



Scorpion II® TL-3 TMA absorbs impacts sequentially.

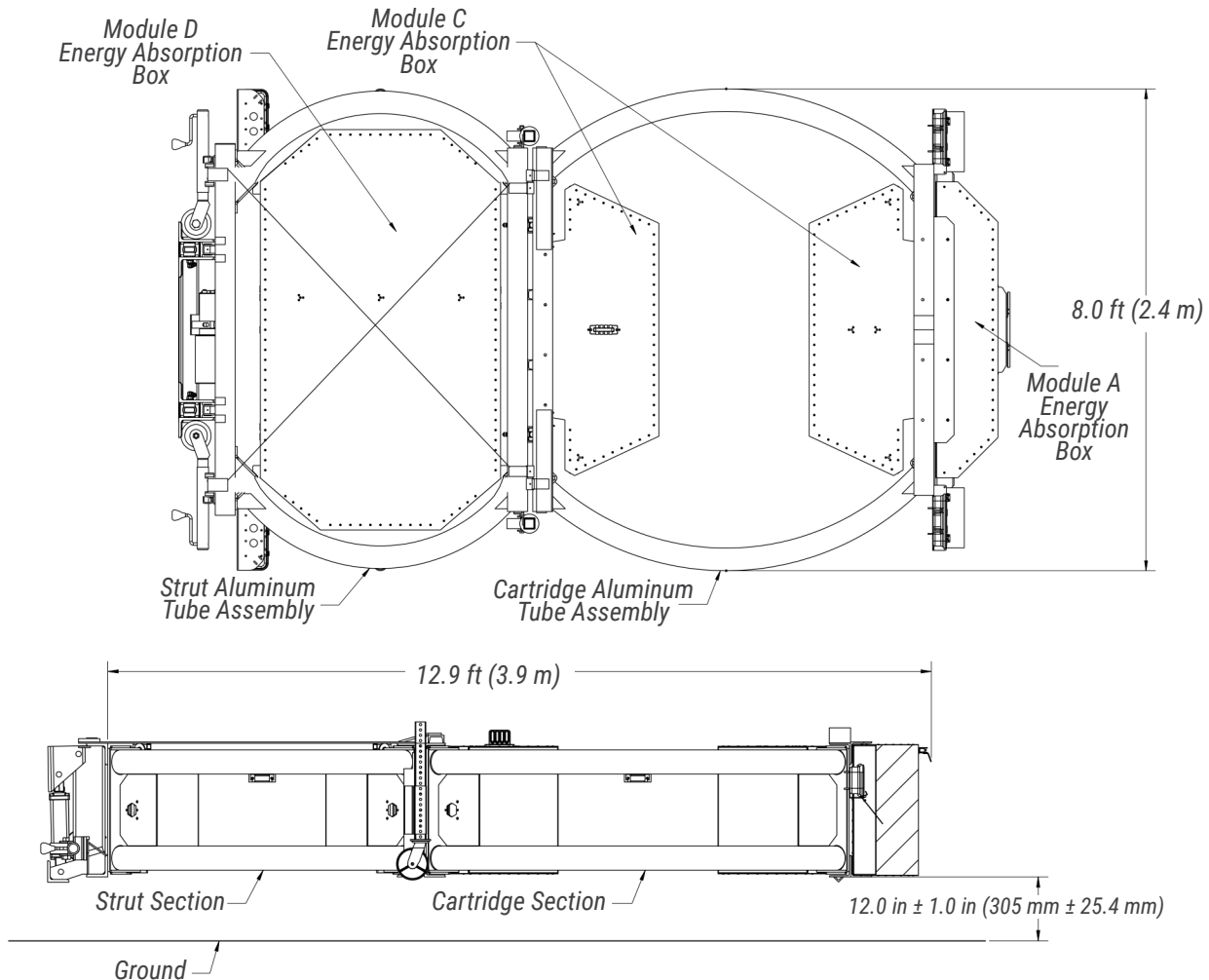





Singapore



176

Sweden

## SAVING LIVES AROUND THE WORLD



United Kingdom



Australia



Taiwan

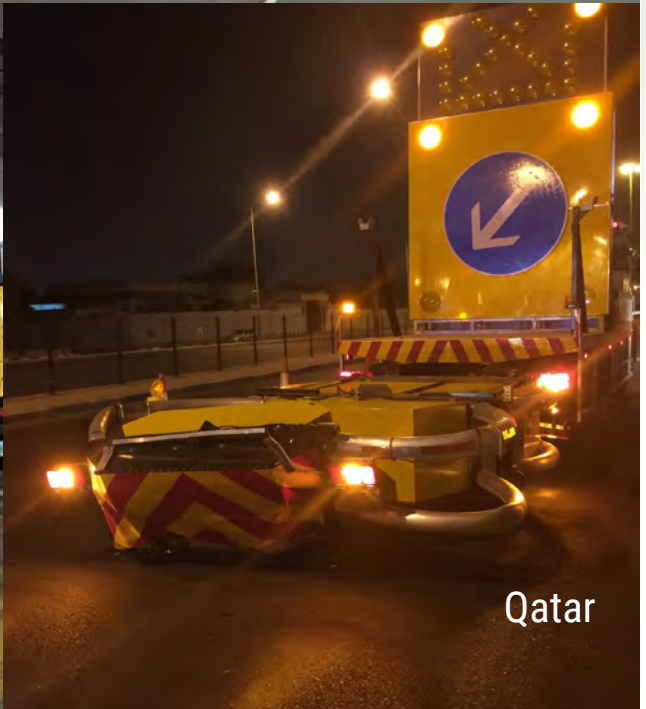

Qatar



# PROTECTING WORKERS AND MOTORIST ON THE HIGHWAY WORLDWIDE



Australia



Korea

## Versatility and Flexibility—TraFFix Devices Offers TWO Different Scorpion TMA Models



**MODEL A**  
The Scorpion TMA Model A utilizes only the cartridge section providing impact protection up to 45 mph (70 km/h). It incorporates a modular design, which can be upgraded to a Model C-90 or Model C (to meet NCHRP-350, TL-3 requirements), by simply adding the strut section.



### SPECIFICATIONS

**MODEL A**  
(NCHRP-350, TL-2)  
Weight 760 lbs. (346 kgs.)  
Length (from back of vehicle)  
Travel/Storage 3' (1 m)  
Deployed 8' 8" (2.65 m)  
Width 8' (2.45 m)  
Height (from ground)  
Travel/Storage 11' (3.35 m)  
Deployed (ground clearance) 1' (.3 m)  
Tests Successfully Passed  
2-50, 2-51



**MODEL C**  
The Scorpion TMA Model C folds over the bed of flat bed, stake bed or dump trucks. The Scorpion TMA Model C provides TL-3 impact protection. Center or side mounts are also available



**MODEL C**  
(NCHRP-350, TL-3)  
Weight 2,200 lbs. (1000 kgs.)  
Length (from back of vehicle)  
Travel/Storage 2' 5" (.74 m)  
Deployed 13' 10" (4.21 m)  
Width 8' (2.45 m)  
Height (from ground)  
Travel/Storage 10' 6" (3.05 m)  
Deployed (ground clearance) 1' (.3m)  
Tests Successfully Passed\*  
3-50, 3-51, 3-52, 3-53  
UK-TD49-07 - 68.5 mph (110 km/h)

\*TraFFix Devices Scorpion TMA has been tested and also PASSED a "worse case" side angle re-directive impact test, that goes beyond all governmental testing requirements. Full details are available upon request.



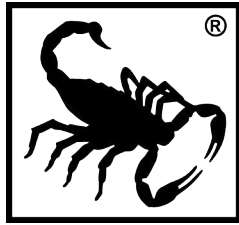

# Scorpion II<sup>®</sup> BLOCKER

Truck & Towable Attenuators



## PROTECT YOUR FIRST RESPONDERS AND YOUR EQUIPMENT

- Over 2,000 documented hits involving Scorpions and thousands of lives saved around the world. Scorpion's design has over twenty years of proven life saving performance on highways around the globe.
- Protect your first responders with the safest, most reliable truck mounted attenuator available today.
- Tested and Eligible with a minimum host truck vehicle weight of only 15,000 lbs (6,804 kg).
- Available with optional Dr. Airbrake<sup>®</sup> automatic braking system, instantly locks brakes of host vehicle upon impact.







# Scorpion II<sup>®</sup> METRO

TL-2 PLUS, 50 mph / 80 kph



**DON'T LEAVE YOUR WORKERS EXPOSED TO THE DISTRACTED DRIVER!**

- MASH TL-2 Plus TMA Tested and Passed at 50 mph (80 kph)
- Only 8 ft (2.44 m) long and 8 ft (2.44 m) wide allowing for easy use in urban areas with a tight turning radius
- Can be mounted on vehicles with a minimum curb weight of 7,500 lbs. 50 mph, (80 kph) protection with smaller host vehicles.
- Infinite weight tested and passed. No maximum weight limit for host vehicle.
- Stored vertical height of less than 10 ft (3.0 m) low pivot



### Full Width Impact Protection

Safely protects and redirects the impacting vehicle away from the "coffin corner" area at the rear of the truck.

### Curved Aluminum Tube Frame

Exceptionally strong, providing protection against nuisance impacts with re-directional capacity along the entire length of the TMA.

### Energy Absorbing Cushions

Aluminum honeycomb core, enclosed by aluminum powder coated modules providing maximum durability and longevity.

### Modular Design

When impacted, the Scorpion II crushes in progressive stages, which results in lower repair costs and easy parts replacement.

### Bucket Truck Crash Kills 3, Severely Injures Telecom Worker

March 28, 2016 • by Staff • E



**PROTECT THEM WITH THE SCORPION II METRO!**



Scorpion II Metro Truck Mounted Attenuator

SCORPION II<sup>®</sup> METRO TRUCK MOUNTED ATTENUATOR





## Scorpion II Metro TL-2 Plus (50 mph/80 kph) Truck Mounted Attenuator

SCORPION II METRO	HIGH PIVOT	LOW PIVOT
Length (of TMA):	8.0' (2.4m)	7.75' (2.36m)
Length (from truck end):	8.83' (2.69m)	10.3' (3.15m)
Width:	8' (2.4m)	8' (2.44m)
Height:	11.2' (3.4m)	10' (3.0m)

### Specification

The Truck Mounted Attenuator (TMA) is a mobile crash cushion attached to the rear of a support vehicle's frame. The TMA may be used on moving shadow trucks, stationary block vehicles, or advanced warning vehicles upstream of a moving or stationary operation. The Metro TMA shall be tested, passed and eligible to MASH TL-2 Plus (50 mph / 80 kph). The TMA can be used on support vehicles with a min. actual/curb weight of 7,500 lbs (3,402 kg) with no upper weight limit (infinite weight). Lighting consists of LED brake, directional, signal and running lights for enhancement of advanced warning to drivers. The Metro TMA has an overall dimension of 8 ft (2.4 m) x 8.0 ft (2.4 m) x 2.0 ft (0.6 m) and has a ground clearance of 12 in ± 1 in (305 mm ± 25.4 mm) when deployed in the horizontal operating position. The Metro TMA consists of two (2) main components: Cartridge and backup/diaphragm frames. The Cartridge section is the energy attenuation component. The aluminum structural weldments bolt to a structural steel diaphragm/backup frame. Metro can be used with all existing Scorpion mounting systems (Standard Mount and Fast-Trak Mount). The Metro TMA can be vertically lifted in a single 90° fold position to the support vehicles bed with a stored height of less than 10 ft (3.0 m) with the low pivot mounting option or 11.2 ft (3.4 m) with the high pivot option. An optional hydraulic powered vertical lift can be utilized with the Metro TMA to deploy a display panel when the Metro TMA is lowered into the use position. The vertical lift is powered by the same on-board hydraulic system that raises the TMA into the stored and/or use position. The vertical lift is sequenced to raise and lower a panel for displaying advanced messages, directional indicators, or other notifications. The Metro TMA can be fitted with an optional Dr. AIR BRAKE auto braking system.



Scorpion II® Metro TL-2 TMA Impacted by 5,000 lbs (2,268 kg) Pick-Up Truck





# Scorpion II<sup>®</sup> METRO-SLIM

Truck Mounted Attenuator | TL2-Plus, 80 kph  
Overall Length: 2.60 m | Overall Width: 1.88 m



PROTECT THEM WITH THE SCORPION II METRO-SLIM!



 TL-2 + Attenuator

## Scorpion II Metro-SLIM TL-2 Plus 50 mph (80 kph) TMA

- Only TL-2 Plus TMA Tested and Passed at 50 mph (80 kph).
- Only 8.5 ft (2.6 m) long and 6.2 ft (1.88m) wide allowing for easy use in urban areas with a tight turning radius.
- Can be mounted on vehicles with a minimum curb weight of 7,500 lbs (3,402 kg) Get 50 mph (80 kph) protection with smaller host vehicles.
- Infinite weight tested and passed. No maximum weight limit for host vehicle.
- Stored vertical height of less than 9.8 ft (3.4 m) with low pivot option.

**Compact Urban Design**

At 2.6 m long X 1.88 m wide, Metro-Slim is ideal for crowded urban streets, leads to less incidental impacts, less down time and more on the road time, protecting workers and motorists.

**Curved Aluminum Tubes**

Exceptionally strong and durable, curved tubes provide re-directional capacity along the entire length of the TMA.

**Energy Absorbing Cushions**

Yellow aluminum honeycomb modules provide additional cushion to absorb the impacting autos energy.

**Modular Design**

The Modular Design of Scorpion II allows for lower repair costs by replacing what's damaged, not the entire cushion.







# Scorpion<sup>®</sup> TMA FAST-TRAK SwiftConnect<sup>™</sup> Mounting System

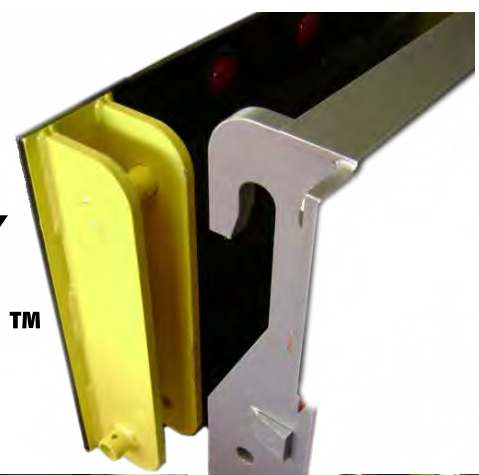

*Fast-Trak Lo Pro works on trucks with Salt Spreaders*

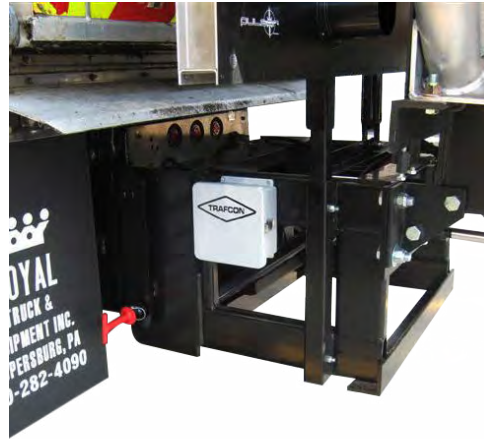

*Fast-Trak w/30" Extension and Vertical Arrowboard Lift*



*Fast-Trak with TL-2 Scorpion*

- Quickly and securely connect the Scorpion II Truck Mounted Attenuator to any heavy-duty vehicle with the Fast-Trak SwiftConnect
- Fast-Trak SwiftConnect Eliminates the need for a single, dedicated Host Vehicle
- Connection/Disconnection is the fastest in the industry
- Fast-Trak SwiftConnect allows any Scorpion TMA to connect in as little as a minute
  1. Back up truck to Fast-Trak SwiftConnect
  2. Align mounting hooks over connection bars and lower in place
  3. Plug in electrical connections
  4. Crank jacks up and rotate for storage and insert locking pins
- Additional traks allow TMA to be installed on multiple vehicles in your fleet
- Safe and secure, the Fast-Trak SwiftConnect is easy to install on any of your flat bed or dump trucks.
- All steel construction provides excellent durability while the swift connection delivers maximum flexibility for your fleet.
- Another innovative engineering advancement from TrafFix Devices, Inc.

## Swift Connection



*Back up truck to Fast-Trak SwiftConnect*



*Align mounting hooks over connection bars and lower in place*



*Plug in electrical connections*



*Crank jacks up and rotate for storage and insert locking pins*



# Scorpion® TMA Mounting and Support

## Fast-Trak Mounting Choices

Fast-Trak SwiftConnect is available in 6", 12", 18", 24", 30" and 36" lengths. Other extension lengths available upon request.



11140-06

6" Fast-Trak SwiftConnect™



11140-12

12" Fast-Trak SwiftConnect™



11150-18

18" Fast-Trak SwiftConnect™



11150-24

24" Fast-Trak SwiftConnect™



11150-30

30" Fast-Trak SwiftConnect™



11150-36

36" Fast-Trak SwiftConnect™



11170-18



11170-30



11170-24



11170-36

\*Part Numbers Represent Fast-Trak SwiftConnect™ with Plate and Traks. Other Configurations available.

18", 24", 30" and 36" Lo Pro Fast-Trak SwiftConnect™

## High Reach Extension Frames

Used to gain additional vertical clearance over truck bed or equipment.



+1.5 ft Height Extender



+3 ft Height Extender



+4 ft Height Extender

Available in 6", 12", 18", 24" & 30" sizes

## Support Choices



Dump Truck Side Support



Flat Bed Side Support



Flat Bed Center Support

SCORPION® TMA MOUNTING AND SUPPORT

Traffix Devices Inc.



# Hydraulic Mounting Systems for Arrow & Message Boards



*Scorpion with 15 Light Arrow Board and Hydraulic Lift*



*Scorpion with Message Board and Hydraulic Lift*



*Traditional Hydraulic Vertical Lift*

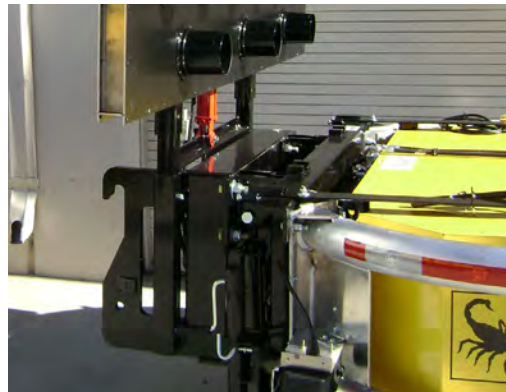

*Fast-Track Hydraulic Vertical Lift*



*Solar Arrow Board with Vertical Lift*



*In-Cab Controller w/ 30' Cable Controls Scorpion™ & Hydraulic lift (Factory or Field Installation)*

Other options available from Traffix Devices, Inc.  
Contact your Authorized Distributor for more details.



# Scorpion II<sup>®</sup> TA

## Towable Attenuator



10002-TL3M-12TA  
(Arrowboards, Uprights Sold Separately)



Scorpion II<sup>®</sup> TL-3 Towable Attenuator  
MASH Tested, Passed and Eligible



### TL-3 Attenuator



- The FIRST Towable Attenuator eligible for MASH, TL-3.
- FHWA Eligibility Letter, CC-138.
- Infinite weight tested and eligible allows the Scorpion II<sup>®</sup> Towable to be used on heavy host vehicles (minimum 12,000 lbs.), with no upper weight limit.
- Scorpion II<sup>®</sup> remained attached to the host vehicle and pintle hook during ALL impact testing.
- Telescoping Anti-Rotational System (TARS) minimizes Scorpion II Towable rotation during angled and offset impacts, preventing cushion separation from host vehicle.
- No additional hardware required for connection to host vehicle.
- The Scorpion II<sup>®</sup> proven modular design crushes in progressive stages allowing quick and economical replacement of damaged parts.
- LED Lights standard on all Scorpion II<sup>®</sup> Towable Attenuators.
- The unique curved design gives full width protection to the back of the host vehicle and shields the deadly “coffin corners” of the truck.
- Rear axle placement improves towable stability and prevents the tail from “bottoming out” on driveways and uneven surfaces.
- MASH tested and eligible with optional display panel, which can be easily attached to Scorpion II<sup>®</sup> Towable Attenuator.



## Scorpion II TL-3 (62.5 mph/100 kph) Towable Attenuator

### Specification:

The Towable Attenuator (TA) is a mobile crash cushion designed with a towable tongue and axle/wheel, that connects directly to the support vehicle's towable connection and using a lunette eye on the attenuator. The TA can be used on support vehicles with a minimum actual/curb weight of 12,000 lbs (5,443 kg) with no upper weight limit (infinite weight). The TA has overall dimensions of 17.8 ft (5.4 m) x 8 ft (2.4 m) x 4.3 ft (1.3 m) with ground clearance of 12.0 in ± 1.0 in (305 mm ± 25 mm). The TA consists of three main components: the towable tongue, front Strut, and rear Cartridge. The towable tongue is positioned nearest to the support vehicle, the Strut is bolted to the tongue and Cartridge. The Cartridge is the rear most component, furthest away from the support vehicle. The towable tongue acts as a standard single point connection under normal towing conditions. The towable tongue is designed with an integral Telescoping Anti-Rotation System (TARS) that is activated when the TA is impacted. The forward sliding action occurs during an impact, upon completion of the full telescoping action the outboard anti-rotation supports come into contact with support vehicle frame plate which in turn prevents angular rotation about the rear of the host vehicle. The Strut consists of four outboard convex aluminum tubes forming an aluminum structural weldment. The aluminum structural weldments bolt directly to the TARS tongue and the rear Cartridge. The structural assembly encompasses the aluminum crush Module D. The Cartridge consists of four outboard convex aluminum tubes forming an aluminum structural weldment. The aluminum structural weldments bolt directly to the struts steel angles and rear towable diaphragm. The TA uses a Cartridge Towable Diaphragm with an axle/wheel attachment for towing the TA. The structural assembly encompasses the two-aluminum crush Module C's. Attached to the rear most end of the Cartridge is the single crush Module A.



Scorpion II® TL-3 Towable Attenuator with Display Panel Impacted by 5,006 lbs (2,271 kg) Pick-Up Truck

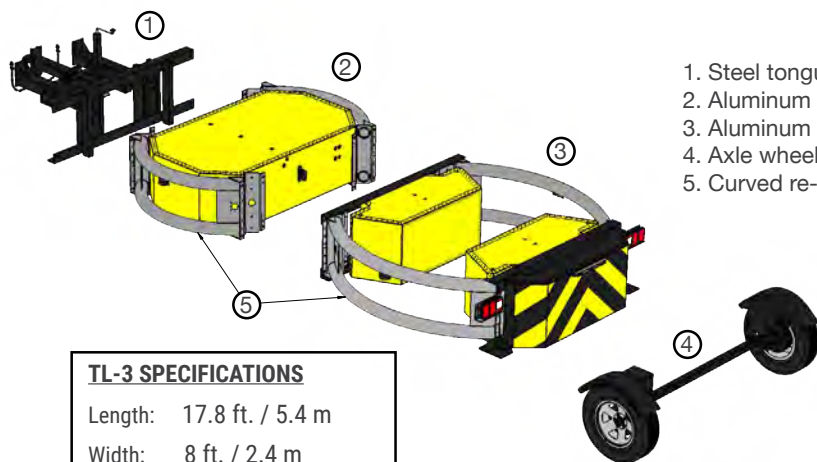

#### TL-3 SPECIFICATIONS

Length: 17.8 ft. / 5.4 m  
 Width: 8 ft. / 2.4 m  
 Height from the ground:  
 12.0 in ± 1.0 in  
 3045 mm ± 25.4 mm

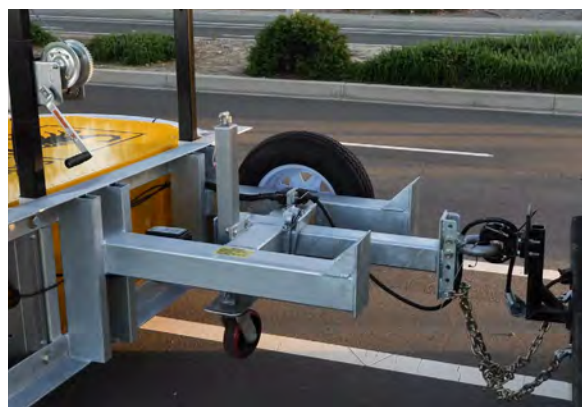



# SLED®

## Sentry Longitudinal Energy Dissipater



### TL-3 End Treatment

- Features:**
- SLED is identical and unchanged as a crash cushion when tested to NCHRP 350, TL-3 and MASH Eligible, TL-3.
  - SLED with NCHRP350 approval is also MASH eligible
  - FHWA Accepted for Shielding the Blunt End of Concrete, Steel and Water Filled Barriers
  - Eligible for use attached to MGS guardrail, CC-155
  - Quick and Easy Set-Up, No Foundation Anchoring, Minimized Installation Exposure Time (under 30 min w/ 2 person team)
  - Cost Effective End Treatment for Concrete, Steel or Water Filled Barriers
  - Universal Transition Quickly and Easily Attaches to a Variety of Barrier Shapes and Sizes
  - SLED's Stout Design Virtually Eliminates Vaulting
  - Narrow Footprint is Ideal for Work Zones or Roads with Minimal Shoulder Spacing
  - Containment Impact SLED Minimizes Debris Field
  - Visual "Drive By" Fill Indicators Quickly Verify Water Module's are Properly Filled
  - FHWA Accepted for Use in Uni and Bi-Directional Applications
  - Internal Steel Cables Help Guide Vehicle After an Impact, creating a Truly "Limited Gating" System
  - SLED End Treatment requires no anchors into roadway or bridge deck



Steel Barrier Attachment



SLED® TL-3 Transports in a Pick-Up Truck



Concrete Barrier Attachment

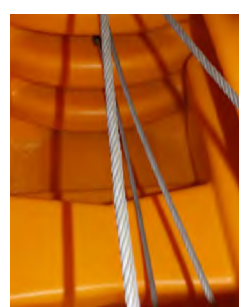

SLED® Internal Cables





# SLED®

Sentry Longitudinal Energy Dissipater



#### DIMENSIONS / WEIGHTS COMPLETE TL-3 SYSTEM

Length	25.25 ft. / 7.7 m
Height	42 in. / 1.1 m
Width:	22.5 in. / 0.6 m
Weight (Empty):	995 lb. / 451 kg
Weight (Full):	6,505 lb. / 2951 kg



## SLED® Sentry Longitudinal Energy Dissipater

The Sentry Longitudinal Energy Dissipater (SLED) is a narrow, non-redirective gating crash cushion. SLED is designed to shield the end of all permanent and temporary portable barrier shapes including concrete, plastic and steel, including MGS guardrail. SLED's unique design incorporates four internal steel cables which help envelop the impacting vehicle, reducing the possibility of secondary accidents. The SLED End Treatment does not require foundation anchor bolts to be attached to the road or bridge deck. The complete crash cushion can be installed quickly, with as little as one pick up truck and two workers on compacted dirt, gravel, decomposed granite, asphalt or concrete.

Each SLED module is manufactured from a high visibility yellow polyethylene that is UV stabilized to minimize degradation. It is designed to deform and rupture on impact, absorbing the energy of the errant vehicle. The SLED has the most versatile transition for shielding all permanent and temporary portable barriers. The combination of hinging and contouring, allows the transition panels of the SLED End Treatment to be attached to narrow, wide or other profile shapes with either converging, or diverging angles, up to 10 degrees.



SLED® TL-3 Impacts Attached to Concrete Median Barrier Wall



# Ease of Installation

**Very few parts  
makes it easy for  
crews to install  
quickly and safely**

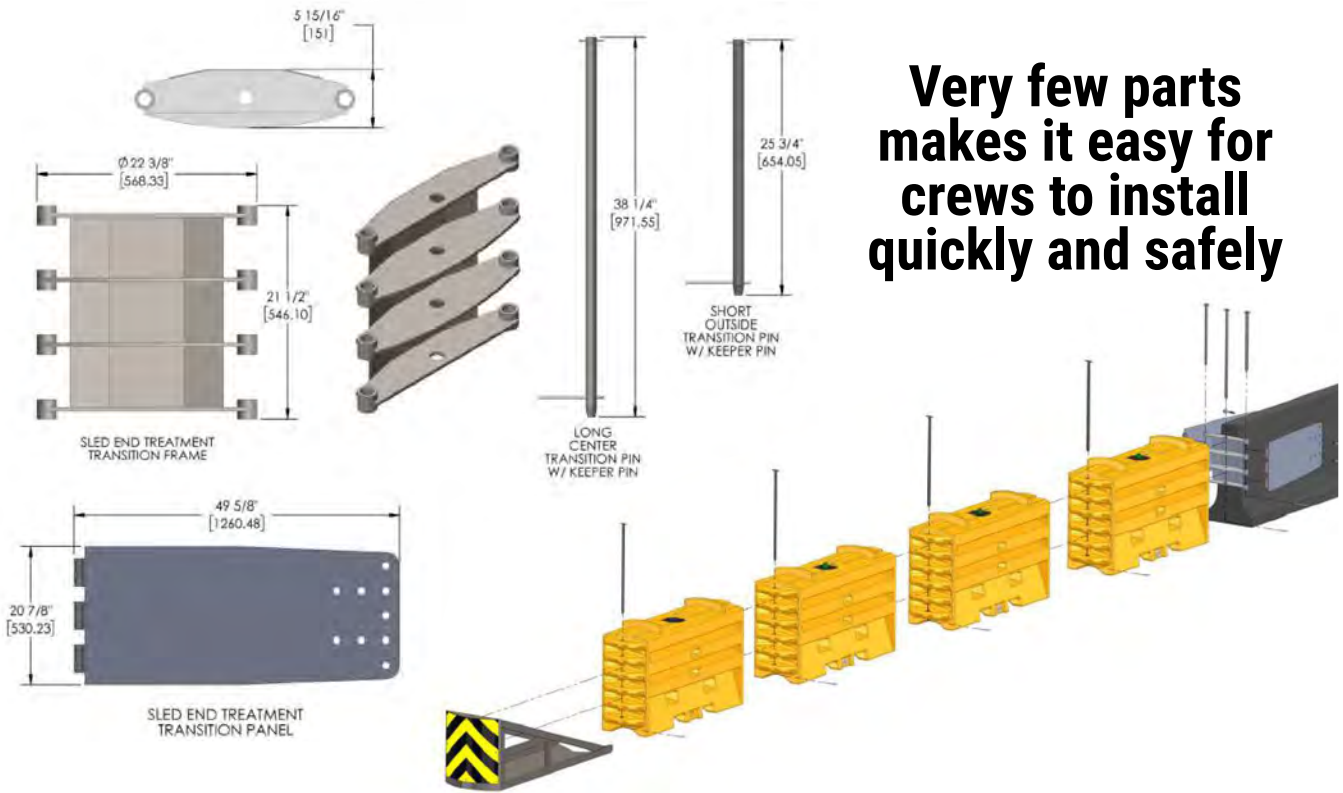

SLED® TL-3 in California



SLED® TL-3 in New Mexico



SLED® TL-2 in Illinois





# SLED<sup>®</sup> Transitions







# SLED<sup>®</sup> mini



### YELLOW SLED MINI MODULE DIMENSIONS / WEIGHTS

Length	77.5 in. / 2 m
Height	32 in. / 0.8 m
Width:	18 in. / 0.5 m
Weight (Empty):	100 lbs. / 45.4 kg
Weight (Full):	1,070 lbs. / 485.3 kg



#45332-Y-TLZ



#45032-Y-CIS



## TL-2 End Treatment

- MASH Eligible as TL-1 & TL-2 when connected to Traffix Water-Cable Barrier
- MASH Eligible as TL-1 & TL-2 End Treatment when connected to concrete median barrier
- Stout Design Eliminates Vaulting of the Impacting Vehicle
- Containment Impact Sled (CIS) Minimizes Debris Field
- Quick and Easy Setup Minimizes Installation and Worker Exposure Time
- No Foundation Anchoring Required, Complete System is Free Standing
- Narrow Width is Ideal for Confined Work Zones and Lower Speed Applications
- Shorter height improves "Line of Sight"



SLED<sup>®</sup> Mini attached to concrete barrier



SLED<sup>®</sup> Mini attached to Traffix Water Wall



## SLED® mini

### Specification:

The SLED® mini is a narrow, non-redirective gating crash cushion. SLED mini is MASH Eligible as an End Treatment when connected to Traffix Water-Cable Barrier™, (TL-1 & TL-2) and concrete median barrier, (TL-1 & TL-2). The SLED mini End Treatment does not require foundation anchor bolts to be attached to the road or bridge deck, The Yellow Module resting in the Containment Impact SLED is required to be filled with water. The SLED mini contains three internal cables. It is designed to deform and rupture on impact, absorbing the energy of the errant vehicle. The complete crash cushion can be installed quickly, with as little as one pick-up truck and two workers, on compacted dirt, gravel, decomposed granite, asphalt or concrete.

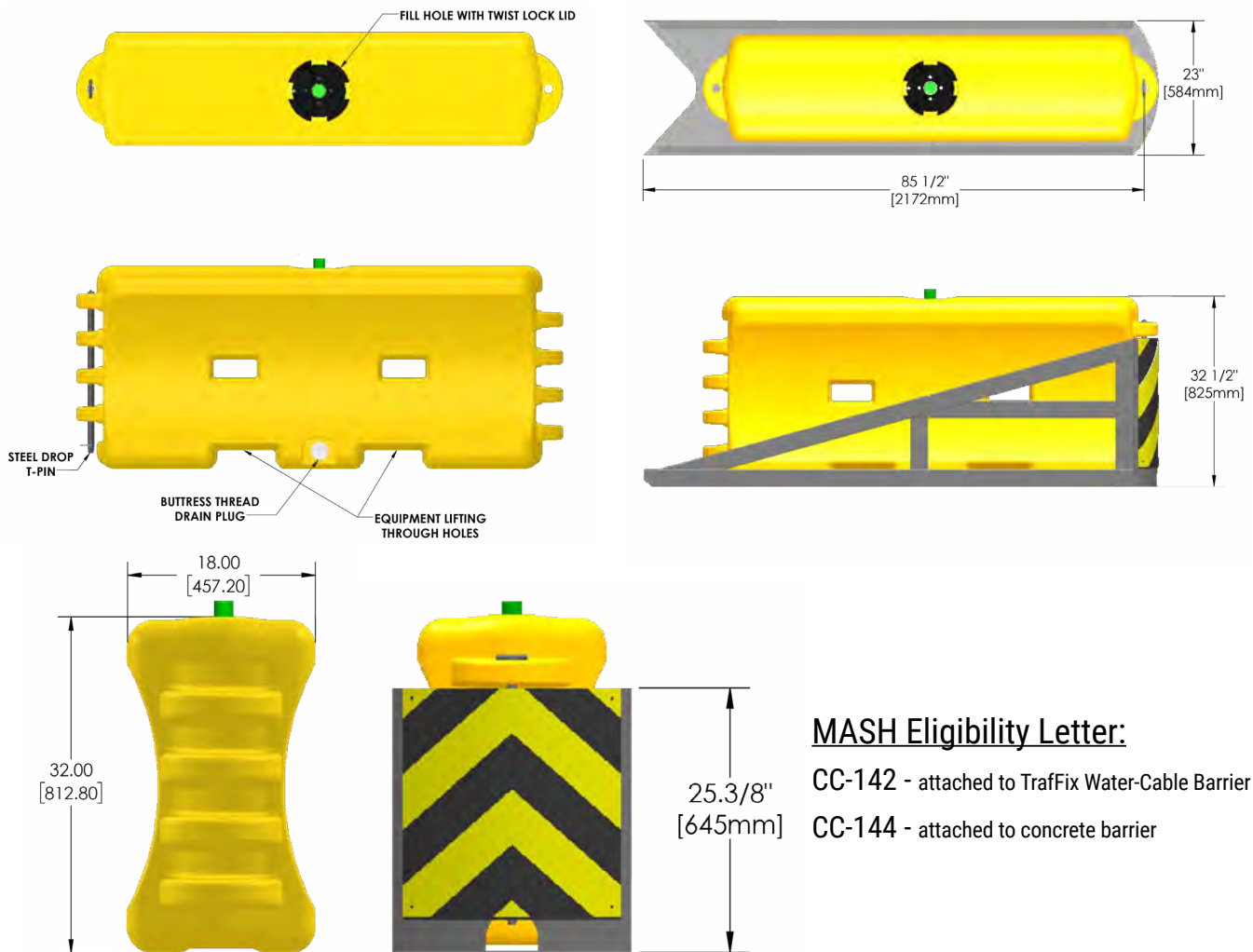

### MASH Eligibility Letter:

- CC-142 - attached to Traffix Water-Cable Barrier
- CC-144 - attached to concrete barrier



# SLED®

## EURO-TERMINAL

*Sentry Longitudinal Energy Dissipater*



**SLED END TERMINAL SYSTEM  
DIMENSION / WEIGHTS**

Length	7.7m
Height	1.1m
Width:	0.6m
Weight (Empty):	451 kg
Weight (Full):	2,951 kg



 P4 End Terminal

**Features:**

- SLED Euro-Terminal Offers a Safe and Effective End Treatment For Turned Down or Blunt Barrier Ends
- EN 1317-4 P4 Accepted for Shielding the Blunt End of Steel, Concrete & Water Filled Barriers
- Quick and Easy Set-Up, No Foundation Anchoring, Minimized Installation Exposure Time
- Cost Effective End Treatment for Concrete, Steel or Water Filled Barriers
- Barrier Specific Transitions Quickly and Easily Attach to the Most Popular Steel Barriers and Concrete
- SLED's Stout Design Virtually Eliminates Vaulting
- Narrow Footprint is Ideal for Work Zones or Roads with Minimal Shoulder Spacing
- Short Length reduces the chance for incidental Contact
- Containment Impact SLED Minimizes Debris Field
- Visual "Drive By" Fill Indicators Quickly Verify Water Module's are Properly Filled
- Internal Steel Cables Link all Components, Thereby Minimizing Vehicle Intrusion Into the Work Zone
- SLED End Treatment Requires no Anchors on Roadway or Bridge Deck



# Tested and Accepted

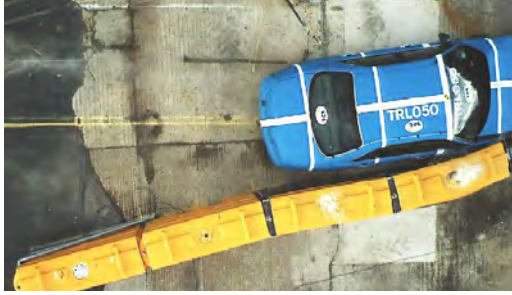

Tested and Accepted: EN1317-4 P4 Impact  
Speed: 110 kph Vehicle Type: 1500 kg Bullet  
Vehicle Impact Angle: 15° Side



Tested and Accepted: EN1317-4 P4 Impact  
Speed: 110 kph Vehicle Type: 1500 kg Bullet  
Vehicle Impact Angle: Head-On Centre

## SLED® EURO-TERMINAL Sentry Longitudinal Energy Dissipater

The SLED EURO-TERMINAL is a narrow water filled attenuation device designed to shield the end of safety barriers in frontal and side impacts. The SLED EURO-TERMINAL's unique Containment Impact Sled (CIS), safely brings an impacting vehicle to a controlled stop and prevents the vehicle from vaulting, while containing the plastic debris within the steel CIS frame structure. The side safety panels and internal steel cables re-direct an impacting vehicle away from the blunt barrier end.

The SLED EURO-TERMINAL is the only free standing attenuation device that has been tested and accepted to EN1317-4 P4 requirements. Since the system is free standing, there are no pavement anchors, bolts or drilling to compromise the integrity of the roadway surface or bridge deck. The complete P4 SLED EURO-TERMINAL can be installed quickly with as little as one lorry and two workers and is designed to be placed on compacted dirt, gravel, decomposed granite, asphalt, or concrete.

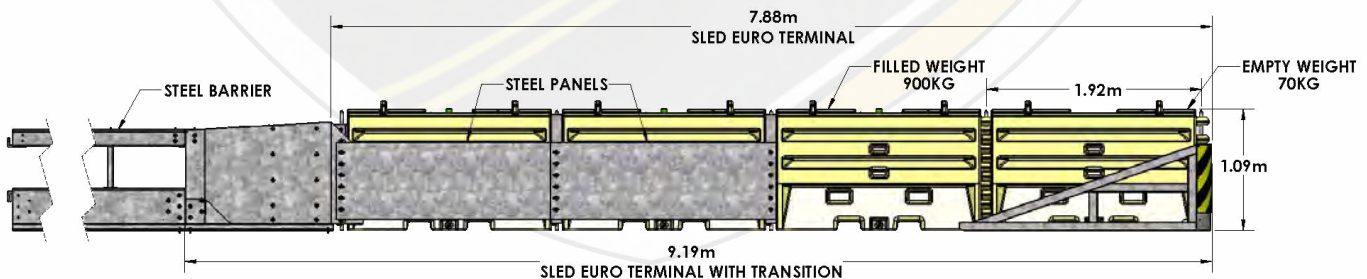

TT 2.1.100  
Head on nose 1/4 offset to roadside  
Vehicle Mass = 900 kg  
Velocity = 100 Km/h

TT 1.3.110  
Head on centre  
Vehicle Mass = 1500 kg  
Velocity = 110 Km/h

TT 4.3.110  
Side, 15 degree  
Vehicle Mass = 1500 kg  
Velocity = 110 Km/h

TT 5.1.100  
Side, 15 degree (reverse impact)  
Vehicle Mass = 900 kg  
Velocity = 110 Km/h

# BIG SANDY®

Impact Attenuator Sand Barrels



Big Sandys perform as tested with break upon impact plastic



#### MASH Eligibility Letter:

MASH Eligible TL-3, Crash Cushion - CC-139

#### NCHRP-350 Approval Letters:

NCHRP-350 Big Sandy, Mixing of Barrels - HNG-14

NCHRP-350 Big Sandy, Roto-Molded - CC-52

NCHRP-350 Big Sandy - CC-52A

NCHRP-350 Big Sandy, Injection Molded - CC-52B

NCHRP-350 Big Sandy, HDPE Injection Molded - CC-52C



## TL-3 Barrier

- Big Sandy is identical and unchanged as a crash cushion when tested to NCHRP 350, TL-3 and MASH Eligible, TL-3.
- Big Sandy twelve barrel array is identical and unchanged when tested to NCHRP 350, TL-3 and MASH Eligible, TL-3.
- Big Sandy barrels are engineered to break upon impact, reducing the chance of lifting or vaulting of the impacting vehicle.
- Three (3) barrels are used to create all weights required in current standard array plans (200, 400, 700, 1400 and 2100 lbs. / 90, 180, 320, 640 and 960 kg).
- Combination barrel utilizes a pedestal base and 200, 400, 700 lbs. (90, 180, 320 kg) top half barrel to obtain weights without using shelves or cone inserts – eliminates leaking sand.
- Simply fill the sand to the molded-in fill line to obtain the correct weight. The molded-in fill line makes external verification of weights easy.
- Reinforced lip prevents barrels from deforming when filled and provides a quick and secure lid fit.
- Big Sandy's stout construction allows for easy moving, lifting and emptying with optional TrafficFix Lifting Ring.



# Now there is an Impact Attenuator Sand Barrel that is easy to move and provides external verification of the barrels correct weight of sand.



Three separate barrels available



Easy lift with Lifting Ring

## Big Sandy® Impact Attenuator Sand Barrels

### Specification:

These specifications describe a plastic barrel which is filled with sand and used in arrays for providing vehicle crash cushions. The Big Sandy is both NCHRP-350 Approved, TL-3 and MASH Eligible, TL-3. The barrels are covered by a plastic lid and have a lifting flange for purposes of attaching a lifting ring to move the barrels. Three separate barrels are available. The largest holds 2,100 lbs (960 kg.); the second largest holds 1,400 lbs. (640 kg.) and the third can be filled to 700 lbs. (320 kg.), 400 lbs. (180 kg.) and 200 lbs. (90 kg.). The third size barrel is assembled in the field by locking two different sizes of half-barrels together and filling to one of three different fill heights as marked on the barrel. The barrels are made of polypropylene and high-density polyethylene UV stabilized molded plastic with a yellow colorant. This plastic combination is engineered to break upon impact, resulting in proper attenuation of the impacting vehicle. All barrels are Q.C. tested for part weight, color, thickness, drain holes, and lid fit. Each plastic barrel comes with a five year, pro-rated repair or replacement warranty against U.V. weathering degradation.



For easy lifting with a forklift, the Big Sandy Lifting Ring is also available

#48001-LR



2,100 lbs. (953 kg.)

#48210-0



1,400 lbs. (635 kg.)

#48140-0



700 lbs. (318 kg.) / 400 lbs. (181 kg.) / 200 lbs. (91 kg.)

#48247-AB

# Typical Sand Barrel Arrays

POSTED SPEED	ROWS												
	1	2	3	4	5	6	7	8	9	10	11	12	
25 MPH 40 KPH	21	14	14										
30 MPH 48 KPH	21	14	14	14									
35 MPH 56 KPH	21	14	14	14	7								
40 MPH 64 KPH	21	14	14	14	7	4							
45 MPH 72 KPH	21	14	14	14	14	7	4						
50 MPH 80 KPH	21	14	14	14	14	7	4	2					
55 MPH 89 KPH	21	14	14	14	7	7	4	2	2				
62 MPH 100 KPH **	21	14	7	7	7	4	4	2					
65 MPH 105 KPH	21	14	14	7	4	4	2		4	2	2	2	2
70 MPH 113 KPH	21	14	14	14	7	4	2		4	2	2	2	2

**BIG SANDY®**  
Impact Attenuator Sand Barrels



Key: Numbers indicate weights in hundreds of pounds required for each sand barrel in the array.

- 21 2,100 lbs = 953 kg
- 14 1,400 lbs = 635 kg
- 7 700 lbs = 318 kg
- 4 400 lbs = 181 kg
- 2 200 lbs = 91 kg

This drawing is an example of a typical array plan and should in no way override what is specified by your Local or State Traffic Engineer. Contact your Local or State Traffic Engineer for specific site recommendations for each situation and location.

\*\* NCHRP 350 and MASH Tested 12 Barrel Array



# Sentry<sup>tm</sup> Water-Cable Barrier

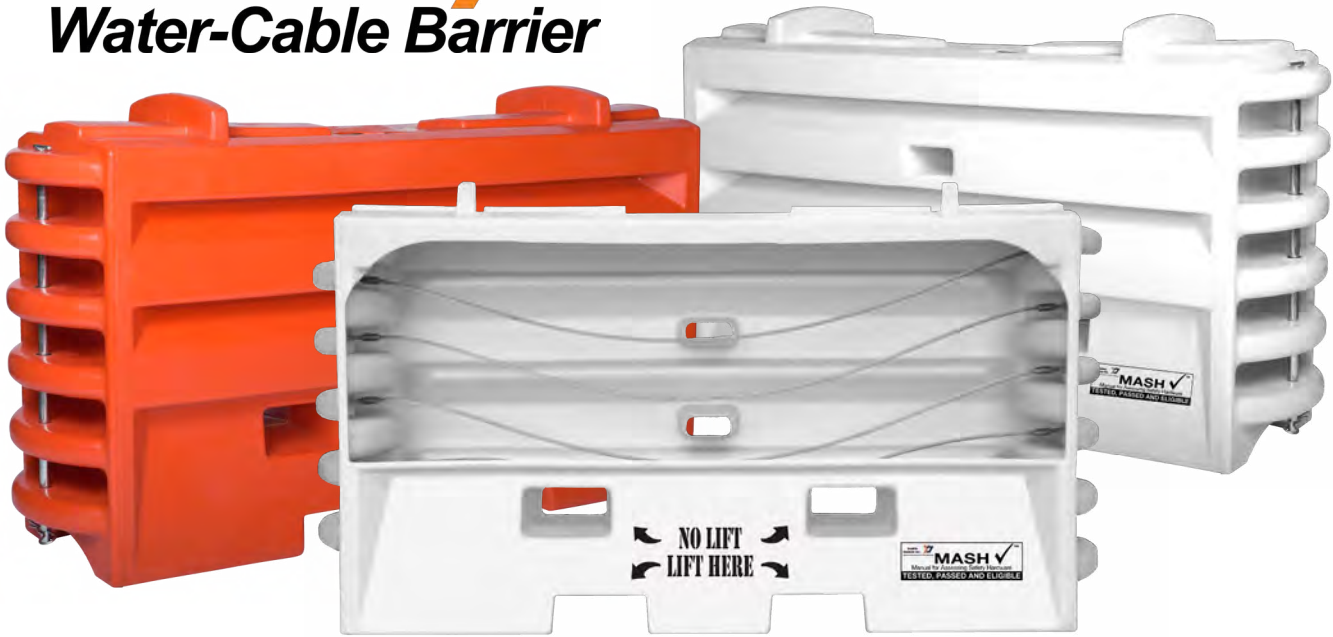

## TL-1, TL-2 & TL-3 Raised Barrier

- The Sentry Water-Cable Barrier is MASH Eligible as a TL-3 Barrier.
- The perfect alternative to heavy concrete barriers requiring special equipment to deploy.
- Ideal for bridge deck work. Lighter than concrete median barriers and no anchors needed.
- Four each 3/8" diameter stranded steel cables to prevent vehicle penetration into the work zone.
- Stacking lugs for easy storage and transport.
- Bushings and cable assemblies are integrally molded into the connecting lugs.
- Easy to transport and easy to install.

### DIMENSION / WEIGHTS

Length: 76 in. / 1.93 m  
 Height: 43 in. / 1.09 m  
 Width: 22.5 in. / .57 m  
 Weight (empty): 215 lbs. / 97.5 kg  
 Weight (full): 2,150 lbs. / 975.2 kg

### MASH Eligibility Letter:

MASH Eligible TL-3 Longitudinal Barrier - B-279



# Sentry™ Water-Cable Barrier

## Sentry Water-Cable Barrier™

### Specification:

Sentry Water-Cable Barrier to be 75.6" (1.9 m) long x 22.5" (0.57 m) wide x 45.8" (1.2 m) tall and molded from polyethylene. Sentry Water-Cable Barrier to be MASH tested, passed and eligible for TL-1, TL-2 & TL-3, 62.1 mph (100 km/hr) longitudinal barrier applications. Individual wall (empty) shall weigh 165 lbs (75 kg) including internal cables and 2,000 lbs. (907 kg) when filled with water. Four 3/8" diameter stranded steel cables are molded into the wall to contain the impacting vehicle during an accident. Standard colors are orange/red and white, product may also be produced in other colors. Sentry Water-Cable Barrier modules are connected together with galvanized steel T-pins passing through a double wall knuckle which minimizes breakage at hinge points. Sentry Water-Cable Barrier shall pivot up to 15 degrees when connected. Sentry Water-Cable Barrier to have one 8" (.2 m) diameter fill hole for quick filling and a twist lock cap for closure. Sentry Water-Cable Barrier will have molded fork lift slots to provide easy movement. Drain plug to be centered on the modules to protect against cracking or breaking and have course buttress threads for quick removal and insertion. Sentry Water-Cable Barrier shall stack for easy movement and storage.

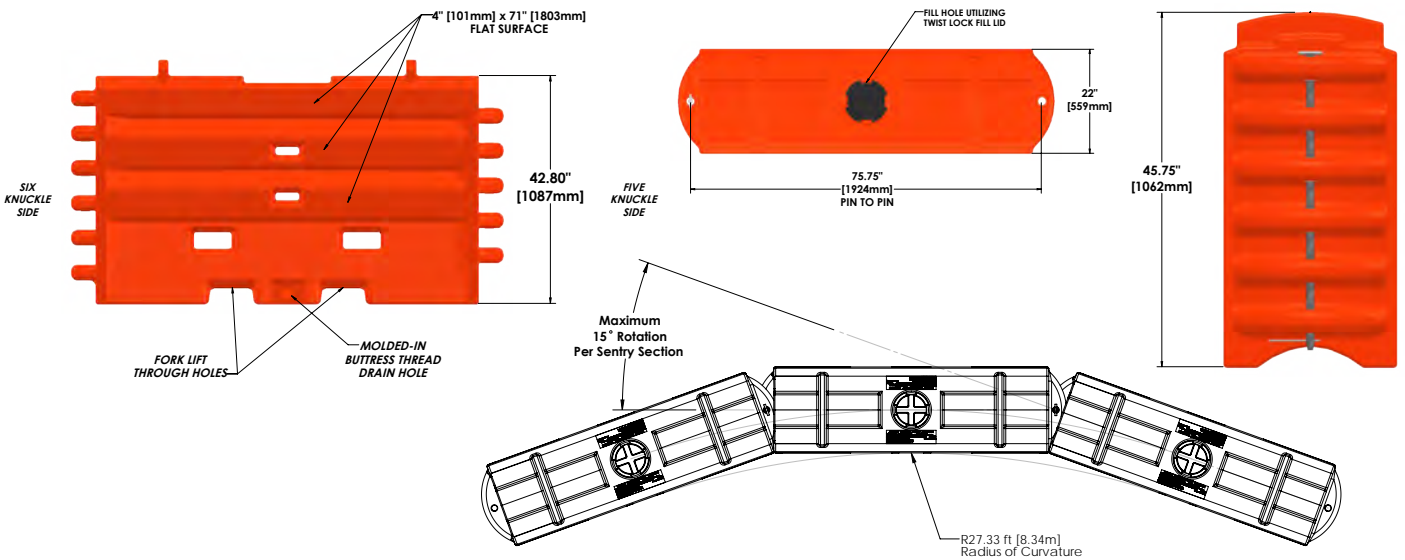

Cutaway Showing Four Integrally Molded Cables & Bushings



Pinned Walls Rotated at 15°



Large 8" diameter fill hole speeds filling process, includes twist-lock plastic cap



1-1/2 Turn, Quick Out Drain Plug w/ Buttress Thread



# TrafFix WATER-CABLE Barrier™

MASH Tested, Passed and Eligible  
TL-1 and TL-2 Barrier



45332-MW



45332-MO

## TL-1 and TL-2 Barrier

### Features:

- TrafFix Water-Cable Barrier has been MASH Tested, Passed and Eligible at TL-1 31 mph (50 km/hr) and TL-2 43.5 mph (70 km/hr) levels.
- Molded in galvanized steel cables (3) strengthens water-cable barrier to resist vehicle penetration during an impact.
- Double wall knuckle design minimizes breakage at hinge points.
- Durable polyethylene plastic with ultra violet additives resist fading, cracking and breaking.
- Hinge design allows for a 30-degree pivot between sections.
- Large 8" fill hole speeds filling process, includes twist-lock plastic cap.
- Tamper resistant drain plug with coarse buttress thread eliminates cross threading and quickly screws in or out in only 2 1/2 turns.
- Includes one steel connection pin that allows sections to be linked together.
- Forklift / pallet jack slots for easy movement and placement.
- Standard colors are orange/red or white - additional colors available upon request.
- MASH Compliant TL-1 & TL-2 with TrafFix Water Wall Fence (B-311).



### DIMENSIONS / WEIGHTS

Length:	73 in. / 1.9 m
Height:	32 in. / 0.8 m
Width:	18 in. / 0.5 m
Weight (empty):	100 lbs. / 45.4 kg
Weight (full):	1,070 lbs. / 485.3 kg



Tamper resistant, offset drain plug with coarse



Large 8" fill hole speeds filling process, includes twist-lock plastic cap



Water-Cable Barrier can be easily moved using a forklift or pallet jack



Water-Cable Barrier with Water-Wall Fence

# Lo-Ro<sup>®</sup> Water-Cable Barrier

MASH Tested, Passed and Eligible at TL-2,  
45 mph (70 kph)

## DIMENSIONS / WEIGHTS

Length: 75.75 in. / 1.92 m

Height: 36 in. / 0.9 m

Width: 22.5 in. / 0.57 m

Weight (empty): 160 lbs. / 72.58 kg

Weight (full): 1,600 lbs / 726 kg

Material: Polyethylene Plastic &  
Galvanized Steel

Colors: Orange/Red, White, Yellow

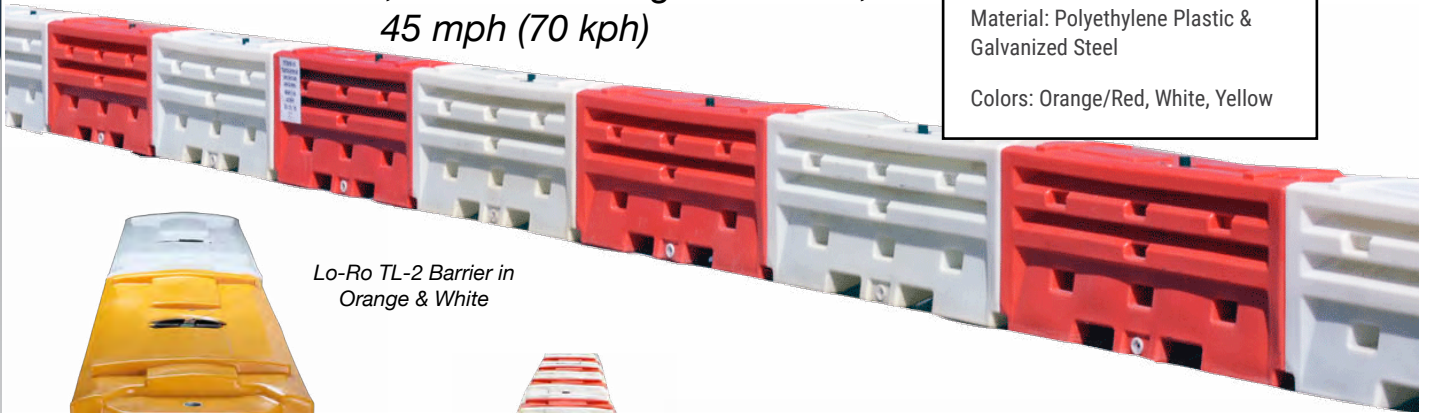

Lo-Ro TL-2 Barrier in  
Orange & White



Interlocking knuckles  
minimize rotation between  
modules



Lo-Ro Water-Cable Barrier shown with MASH  
Compliant Lo-Ro TL-2 SLED Treatment



MASH Compliant Lo-Ro TL-2 SLED  
End Treatment comes standard with  
reflective sheeting and directional  
pattern options

LO-RO<sup>®</sup> WATER-CABLE BARRIER



## TL-1 and TL-2 Barrier

- Stout design for maximum stability & durability
- Lo-Ro<sup>®</sup> TL-2 is designed for applications where low deflection is desired
- Reduces the clear zone requirement which provides an additional margin of safety for workers in the work zone
- Lower profile, 36" (915 mm) height provides increased visibility for motorists in urban areas
- Lowest deflection MASH TL-2 Water-Filled Barrier at only 11.8 ft. (3.6 m)
- SLED Lo-Ro tested and passed MASH TL-2, as End-Treatment to Lo-Ro Barrier
- Interlocking knuckles minimizes rotation between modules
- Three galvanized steel cables assist with minimizing penetration into the work zone
- Molded-In stacking lugs allow for easy storage & transport





# Water-Wall™

## Longitudinal Channelizing Device



#45032-O  
Orange Water-Wall



 TL-2 LCD

#45032-W  
White Water-Wall

### Features:

- MASH Eligible, TL-2 Longitudinal Channelizing Device
- NCHRP-350 Tested and Passed, TL-1 Barrier Wall, TL-2 Longitudinal Channelizing Device and TL-3 Barricade
- Durable Linear low density polyethylene plastic minimizes cracking and breaking
- Double wall knuckle design minimizes breakage at hinge points
- Hinge design allows for a 30-degree pivot between sections
- Large 8" fill hole speeds filling process, includes twist-lock plastic cap
- New tamper resistant, offset drain plug with coarse buttress thread – screws in or out in only 2 1/2 turns
- Includes one steel connection pin & Keeper pin per wall that allows sections to be locked together
- Forklift and pallet jack slots are molded in for easy movement
- Standard colors are orange/red or white – additional colors available upon request
- Accepts the Water-Wall Chain Link Fence for additional job site security

### DIMENSIONS / WEIGHTS

Length:	73 in. / 1.9 m
Height:	32 in. / 0.8 m
Width:	18 in. / 0.5 m
Weight (empty):	80 lbs. / 36.3 kg
Weight (full):	1,110 lbs. / 503.5 kg



30-degree pivoting hinge design allows the Traffix Water-Wall to handle curved roads

## Water-Wall™ Water Filled LCD

### Specification:

Water-Wall to be 73" long x 32" tall x 18" wide and molded from linear low density polyethylene. Water-Wall to be MASH Eligible as a Longitudinal Channelizing Device, TL-2. Individual wall shall weigh 80 lbs. empty and 1,050 lbs. filled. Standard colors are white or orange. Water-Wall sections are connected together with galvanized steel T-pins passing through a double wall knuckle which minimizes breakage at hinge points. Wall shall pivot up to 30 degrees when connected. Water-Wall to have one 8" diameter fill hole for quick fill and a twist lock cap for closure. Water-Wall will have molded through holes to provide easy movement. Drain plug to be offset to protect against cracking or breaking and have coarse buttress threads for quick removal and attachment. Water-Walls shall stack for easy movement and storage.



Water-Wall stacks for storage and transportation



Water-Wall can be easily lifted and placed using a forklift or pallet jack



Water-Wall can pivot 30-degrees and be locked together with steel connection pins



Water-Wall Fence can be easily attached to Water-Wall for additional job-site security.



Large 8" fill hole speeds filling process, includes twist-lock plastic cap



New tamper resistant, offset drain plug with coarse buttress thread

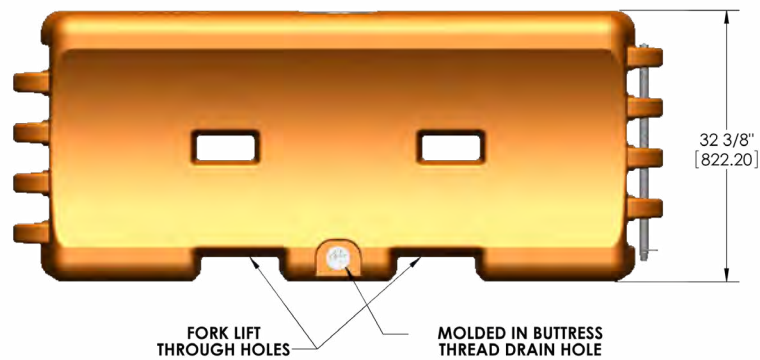

**MASH Eligibility Letter:**  
TL-2 Longitudinal Channelizing Device - WZ-358

**NCHRP 350 Approved As:**  
TL-1 Longitudinal Barrier - HSA-10/B-130  
TL-2 Longitudinal Channelizing Device - HSA-10/WZ-224  
TL-3 Barricade - HSA-10/WZ-224



# WWF™

## Water-Wall Fence



Water-Wall Fence Rotates up to 30° Degrees



T-Pin Connects Wall to Wall and Fence to Fence



Secure Pedestrian entry with a 6' Single Gate, or Drive-Thru entry with a 12' Double Gate



Description	Dimensions
WW Fence Panels	4' h x 6' w / 1.22 m x 1.83 m
6' Single Gate (includes two Gate Attachment Frames)	6' h x 6' w / 1.83 m x 1.83 m
12' Double Gate (includes two Gate Attachment Frames)	6' h x 12' w / 1.83 m x 3.66 m
Gate Attachment Frame T-Pin with Keeper Pin	6' / 1.83 m
Water-Wall (White)	32" h x 73" w / 0.8 m x 1.85 m
Water-Wall (Orange)	32" h x 73" w / 0.8 m x 1.85 m



Ideal for vertical construction. Secure and easy to deploy.



Fence can be Screened for Greater Security



# URBANITE®

Ideal for Crowd Control and Pedestrian Safety

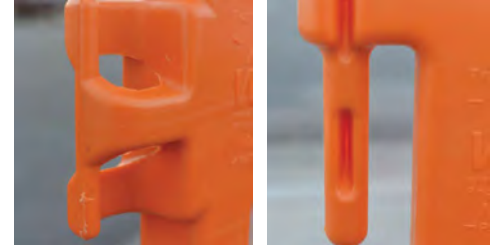

The Blow Molded Connectors Provide Strength and Security



Customizable



**Orange Urbanite Pedestrian Barricade**  
57000-UO

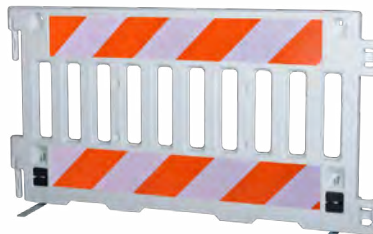

**White Urbanite Pedestrian Barricade with Diamond Grade Right Hand Stripe**  
57000-VW-333



Stacks easily for transport and storage

## TL-3 LCD

- Two legs deploy quickly for fast set-up.
- Leg turns parallel to wall for storage and stacking.
- Made of UV stabilized, high density polyethylene, the linkable Urbanite™ Walls quickly and easily link together in 6 foot sections.
- Weighing only 23 lbs., yet durable, non-flexible and strong
- Lightweight design makes the Urbanite easy to lift on and off the truck and easy to connect.
- The ten molded-in vertical windows reduce wind load, add strength and stability, and reduce overall weight of the Urbanite.
- Two recessed areas measuring 8" wide x 53" long on each side of the Urbanite accommodate sponsorship or advertising of your event.
- Standard colors are orange and white. Custom colors also available upon request.
- The Urbanite is available with the optional Step-N-Deploy leg set for ADA Compliant applications.
- MASH Eligible as a TL-3 longitudinal device, WZ-340
- Optional reflective sheeting available on request



Legs out for use

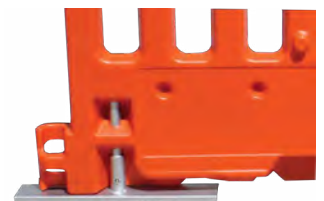

Legs in for storage and transport

### DIMENSIONS / WEIGHT

Length:	72 in. / 1.2 m
Height:	38 in. / 1 m
Width:	3 in. / 0.8 m
Weight:	23 lbs. / 10.4 kg
Material:	UV stabilized polyethylene





**TL-3 LCD**

**Series 57000 Traffix ADA Wall™**

- ADA compliant barricade
- Ergonomic handrail provides a comfortable and secure guide through the workzone
- Locations for two (2) Barricade Lights
- Protect pedestrians from workzone hazards
- Four (4) molded-in Stacking lugs for secure transport and storage
- Two standard colors available: Orange and White
- Custom colors available upon request
- UV inhibitors to minimize fading
- Made of flexible high density polyethylene
- Stackable for easy storage and transportation
- Available with various size and types of reflective sheeting
- Parades/crowd control
- Pedestrian traffic control
- Barricade construction work zones
- Blow Molded connectors provide strength and flexibility
- MASH Eligible as a TL-3 longitudinal channelizing device, WZ-340



*Two Step-N-Deploy Legs Make Set-up Quick, Easy and Safe*



*ADA Compliant*

57000-AW



57000-AO

**Creating a Continuous Hand guided Safe Passage Through the Workzone**



*ADA Wall™ options*

DIMENSIONS / WEIGHT	
Length:	72 in. / 1.2 m
Height:	38 in. / 1 m
Width:	3 in. / 0.8 m
Weight:	23 lbs. / 10.4 kg
Material:	UV stabilized polyethylene







FOLLOW US



We accept Visa, MasterCard and American Express



DISTRIBUTED BY:



**TrafFix  
Devices Inc.**

*Engineered Products for Safer Highways*



160 Avenida La Pata, San Clemente, CA 92673  
phone: 949.361.5663 fax: 949.361.9205  
email: [info@traffixdevices.com](mailto:info@traffixdevices.com)  
[www.traffixdevices.com](http://www.traffixdevices.com)

© Copyright 2023 TrafFix Devices, Inc.

TrafFix® and Scorpion® are trademarks of TrafFix Devices, Inc. U.S. Patent Numbers 6,024,341 and 6,581,992 B1 Licensed Under U.S. Patents 6,092,949 and 6,481,920 TrafFix®, Water-Wall™ are trademarks of TrafFix Devices, Inc. U.S. patents pending.

The products illustrated or described in this catalog are covered by the following U.S. Patent Numbers:  
309,585; 327,658; 4,980,984; 5,026,204; 5,201,599; 5,446,984, 5,540,007, 5,560,732; 5,611,509; 5,624,092; 5,732,911.  
Other U.S. and international patents pending.